

# DTH HAMMER 5"

DESCO INC. is at your solution and service.

Desco Inc.(HQ/Manufacturer)

HEAD OFFICE: 1240-1, Ok-Dong, Gwangsan, Gwangju, Korea

TEL : 82.62.952.4564 / FAX : 82.62.953.1593

EXPORT DIVISION

2607 jidong, Lottecastle, 76, Soongin-Dong, Jongno-Gu, Seoul, Korea

TEL : 82-2-3670 6400 / FAX : 82-2-3670 6399

E-mail : desco@desco-inc.com

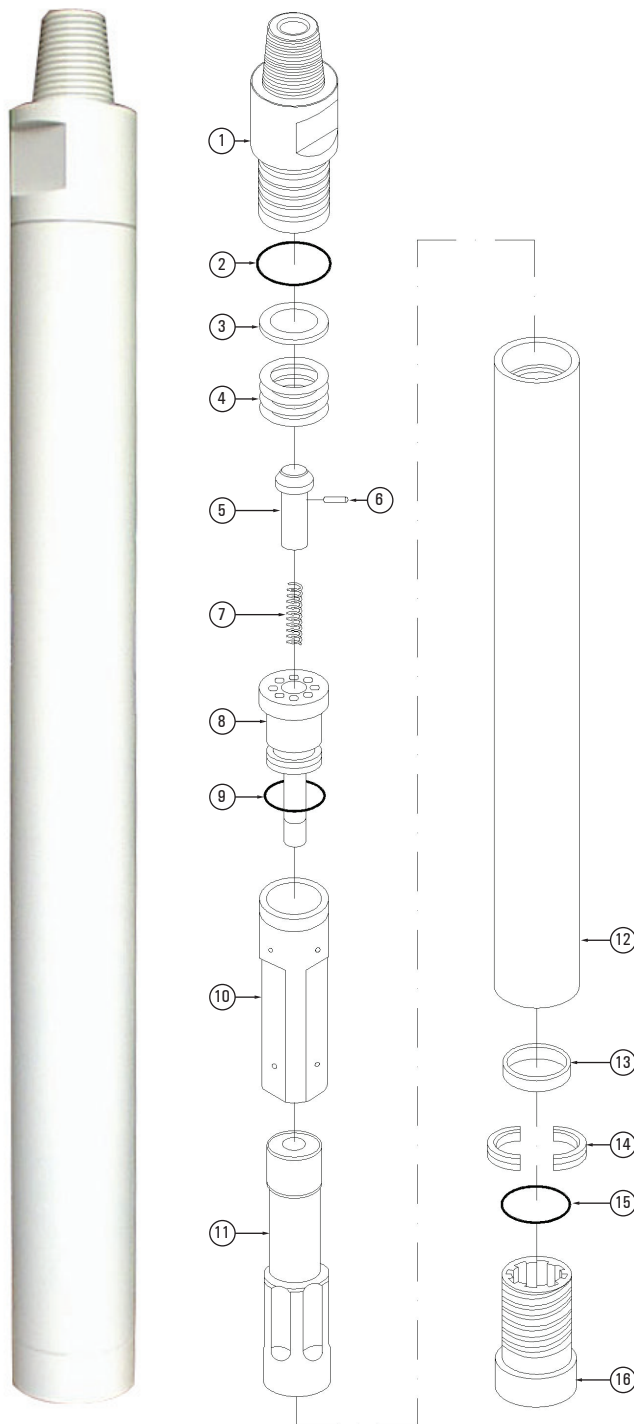

## MODEL TD50 SHANK TYPE DHD350

No	Part Name	Part No
1	Back head	5.0T-01
2	B.H. O-ring	5.0T-01-1
3	Space ring	5.0T-03-1
4	Disk Spring	5.0T-05-1
5	Check valve	5.0T-06
6	Chock	5.0T-06-1
7	C.V spring	5.0T-06-2
8	Air distributor	5.0T-08
9	A.D. O-ring	5.0T-08-1
10	Inner cylinder	5.0T-10
11	Piston	5.0T-11
12	Case	5.0T-12
13	Piston retainer ring	5.0T-11-1
14	Bit. retainer ring	5.0T-19
15	Bit. ret. O-ring	5.0T-19-1
16	Chuck	5.0T-20

### SPECIFICATION

DTH Hammer	5" Hammer
Backhead Thread	API 3*1/2 REG. Pin
Length	1,112mm
Outside Diameter	Dia. 121mm
Weight	68kg
Shank Type	DHD350, SD5, QL5

### AIR CONSUMPTION CHART

150 PSI (10.5bar)	285CFM
250 PSI (17.5bar)	520CFM
350 PSI (24.5bar)	750CFM

### Notice

The specification & drawing is based on IR shank.  
So, Inner parts & specification can be different as the type of the other shanks.

# DTH HAMMER 5"

DESCO INC. is at your solution and service.

Desco Inc.(HQ/Manufacturer)

HEAD OFFICE: 1240-1, Ok-Dong, Gwangsan, Gwangju, Korea

TEL : 82.62.952.4564 / FAX : 82.62.953.1593

EXPORT DIVISION

2607 jidong, Lottecastle, 76, Soongin-Dong, Jongno-Gu, Seoul, Korea

TEL : 82-2-3670 6400 / FAX : 82-2-3670 6399

E-mail : desco@desco-inc.com

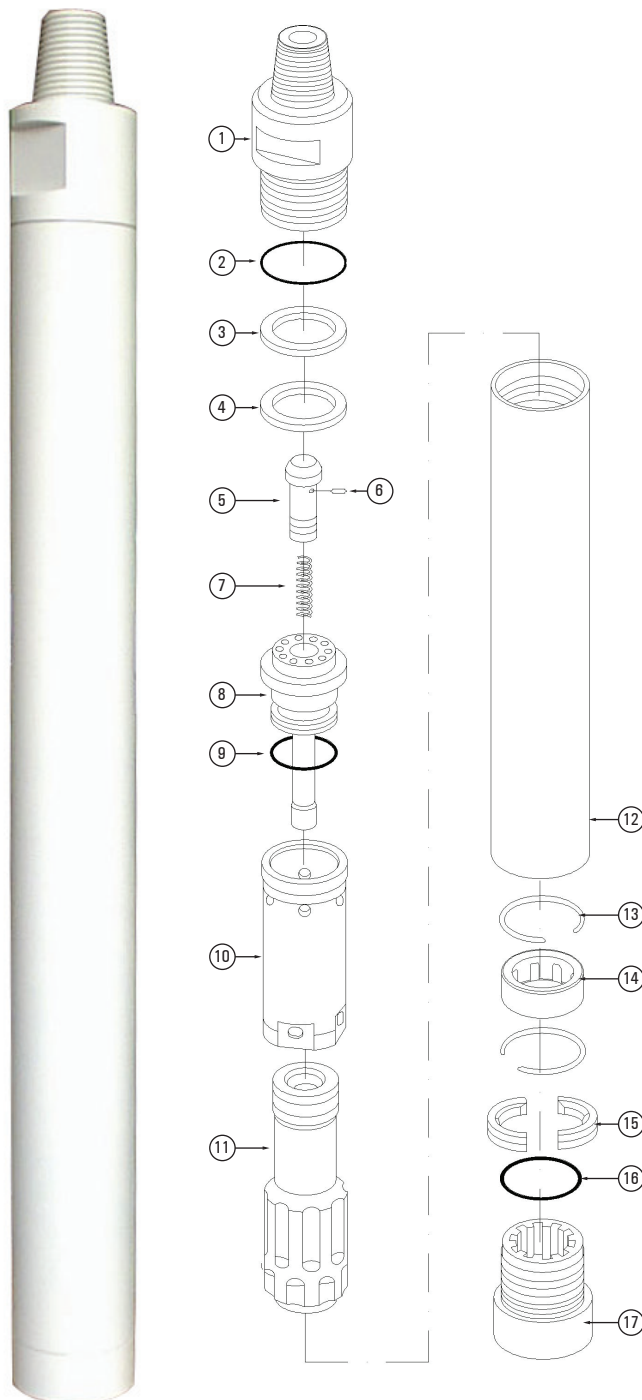

## MODEL ACE50 SHANK TYPE QL50

No	Part Name	Part No
1	Back head	5.0A-01
2	B.H. O-ring	5.0A-01-1
3	Space ring	5.0A-03-1
4	Make-up ring(urethane)	5.0A-04-1
5	Check valve	5.0A-06
6	Chock	5.0A-06-1
7	C.V spring	5.0A-06-2
8	Air distributor	5.0A-08
9	A.D. O-ring	5.0A-08-1
10	Inner cylinder	5.0A-10
11	Piston	5.0A-11
12	Case	5.0A-12(Q)
13	Piston retainer ring	5.0A-11-1
14	Bearing	5.0A-14(Q)
15	Bit. retainer ring	5.0A-19(Q)
16	Bit. ret. O-ring	5.0A-19-1
17	Chuck	5.0A-20(Q)

### SPECIFICATION

DTH Hammer	5" Hammer
Backhead Thread	API 3*1/2 REG. Pin
Length	1,112mm
Outside Diameter	Dia. 121mm
Weight	68kg
Shank Type	DHD350, SD5, QL5

### AIR CONSUMPTION CHART

150 PSI (10.5bar)	285CFM
250 PSI (17.5bar)	520CFM
350 PSI (24.5bar)	750CFM

### Notice

The specification & drawing is based on IR shank.  
So, Inner parts & specification can be different as the type of the other shanks.

# DTH HAMMER 5"

DESCO INC. is at your solution and service.

Desco Inc.(HQ/Manufacturer)

HEAD OFFICE: 1240-1, Ok-Dong, Gwangsan, Gwangju, Korea

TEL : 82.62.952.4564 / FAX : 82.62.953.1593

EXPORT DIVISION

2607 jidong, Lottecastle, 76, Soongin-Dong, Jongno-Gu, Seoul, Korea

TEL : 82-2-3670 6400 / FAX : 82-2-3670 6399

E-mail : desco@desco-inc.com

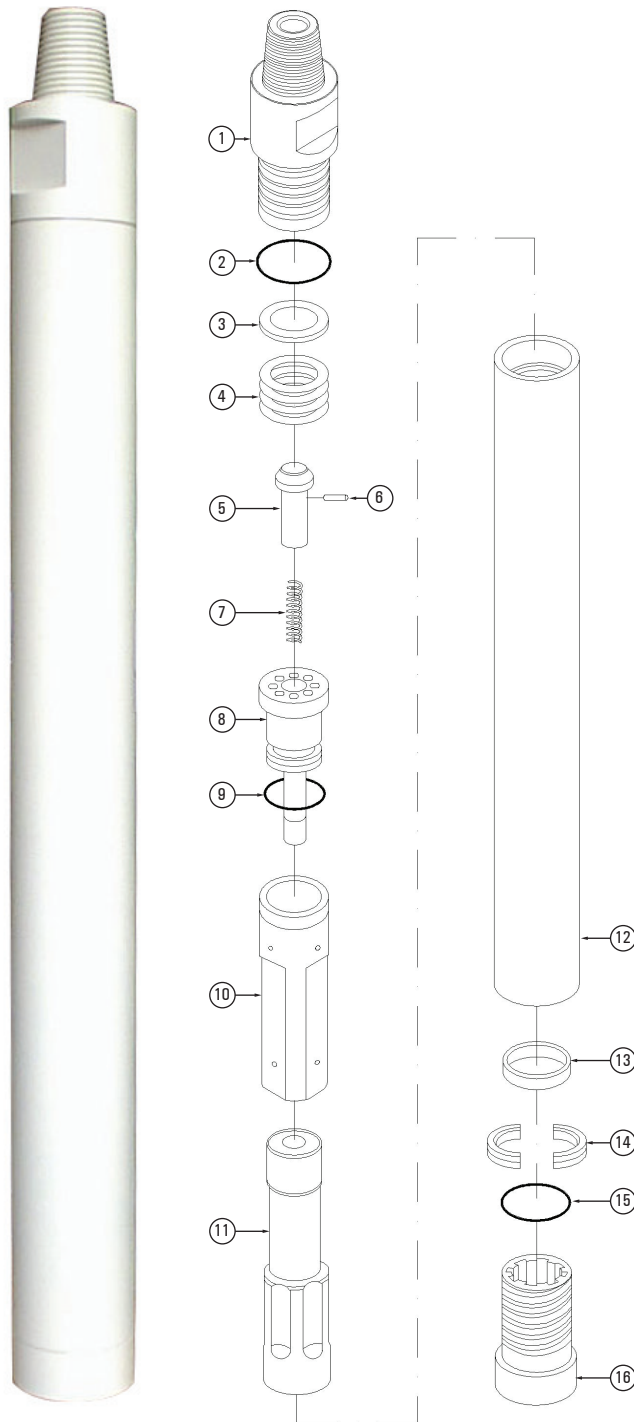

## MODEL TD50 SHANK TYPE SD5

No	Part Name	Part No
1	Back head	5.0T-01
2	B.H. O-ring	5.0T-01-1
3	Space ring	5.0T-03-1
4	Disk Spring	5.0T-05-1
5	Check valve	5.0T-06
6	Chock	5.0T-06-1
7	C.V spring	5.0T-06-2
8	Air distributor	5.0T-08
9	A.D. O-ring	5.0T-08-1
10	Inner cylinder	5.0T-10
11	Piston	5.0T-11
12	Case	5.0T-12
13	Piston retainer ring	5.0T-11-1(S)
14	Bit. retainer ring	5.0T-19(S)
15	Bit. ret. O-ring	5.0T-19-1(S)
16	Chuck	5.0T-20(S)

### SPECIFICATION

DTH Hammer	5" Hammer
Backhead Thread	API 3*1/2 REG. Pin
Length	1,112mm
Outside Diameter	Dia. 121mm
Weight	68kg
Shank Type	DHD350, SD5, QL5

### AIR CONSUMPTION CHART

150 PSI (10.5bar)	285CFM
250 PSI (17.5bar)	520CFM
350 PSI (24.5bar)	750CFM

### Notice

The specification & drawing is based on IR shank.  
So, Inner parts & specification can be different as the type of the other shanks.